

Write your name here

Surname

Other names

Centre Number

Candidate Number

Edexcel GCE

Physics

Advanced Subsidiary

Unit 2: Physics at Work

Friday 20 January 2012 – Morning

Time: 1 hour 30 minutes

Paper Reference

6PH02/01

You do not need any other materials.

Total Marks

Instructions

- Use **black** ink or ball-point pen.
- **Fill in the boxes** at the top of this page with your name, centre number and candidate number.
- Answer **all** questions.
- Answer the questions in the spaces provided – *there may be more space than you need.*

Information

- The total mark for this paper is 80.
- The marks for **each** question are shown in brackets – *use this as a guide as to how much time to spend on each question.*
- Questions labelled with an **asterisk** (*) are ones where the quality of your written communication will be assessed – *you should take particular care with your spelling, punctuation and grammar, as well as the clarity of expression, on these questions.*
- The list of data, formulae and relationships is printed at the end of this booklet.
- Candidates may use a scientific calculator.

Advice

- Read each question carefully before you start to answer it.
- Keep an eye on the time.
- Try to answer every question.
- Check your answers if you have time at the end.

Turn over ►

P39848A

©2012 Pearson Education Ltd.

1/1/1/1/



PEARSON

SECTION A

Answer ALL questions.

For questions 1–10, in Section A, select one answer from A to D and put a cross in the box . If you change your mind, put a line through the box and then mark your new answer with a cross .

1 Which of the following electromagnetic radiations has the lowest frequency?

- A gamma
- B infrared
- C ultraviolet
- D X-rays

(Total for Question 1 = 1 mark)

2 When light from a distant star reaches us on Earth, its wavelength appears shifted towards the red end of the spectrum. This is because

- A the distance travelled by each successive wave has increased.
- B the frequency of the light emitted has decreased.
- C the speed of the star has increased.
- D the star is emitting longer wavelengths.

(Total for Question 2 = 1 mark)

3 Two loudspeakers produce identical sounds of frequency 440 Hz which superpose to produce a standing wave. Adjacent nodes are formed 0.75 m apart.

Select the correct statement about the waves.

- A The frequency heard is 880 Hz.
- B The speed of the waves is 165 m s^{-1} .
- C The wavelength of the waves is 1.5 m.
- D The waves are travelling in the same direction.

(Total for Question 3 = 1 mark)



- 4 The diagram shows an experiment set up to demonstrate two-source interference, using microwaves of wavelength λ .

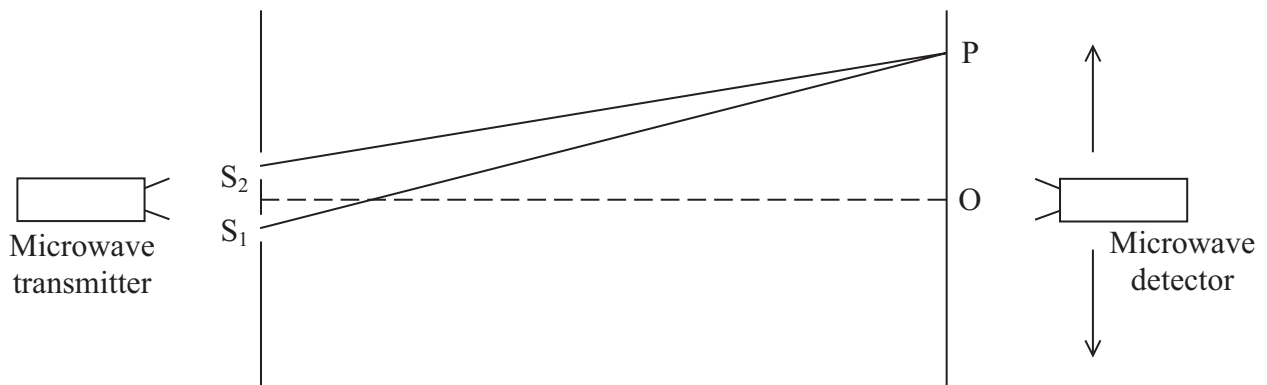

The detector is moved from O in the direction of the upwards arrow. The first position where the signal is a minimum is P.

The equation that correctly determines the position of P is

- A $OP = \lambda$
- B $OP = \lambda/2$
- C $S_1P - S_2P = \lambda$
- D $S_1P - S_2P = \lambda/2$

(Total for Question 4 = 1 mark)

- 5 During a thunderstorm, a flash of lightning resulted in 600 000 C of charge flowing in a lightning conductor in a time of 40 ms. The current in the conductor was

- A 1.5×10^4 A
- B 2.4×10^4 A
- C 1.5×10^7 A
- D 2.4×10^7 A

(Total for Question 5 = 1 mark)

- 6 The unit of potential difference can be expressed as

- A $C s^{-1}$
- B $J C^{-1}$
- C $A \Omega^{-1}$
- D $J A^{-1}$

(Total for Question 6 = 1 mark)



- 7 A steady potential difference is applied across a variable resistor that is kept at a constant temperature.

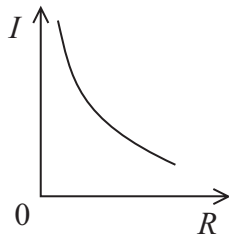

A

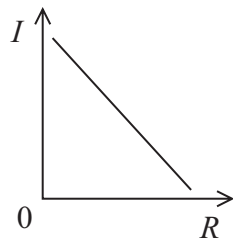

B

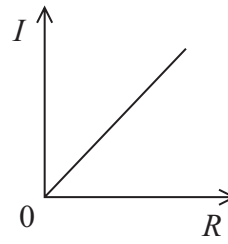

C

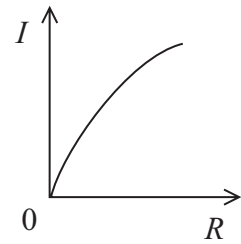

D

The graph which represents the relationship between the resistance R of the variable resistor and the current I through it is

- A**
- B**
- C**
- D**

(Total for Question 7 = 1 mark)

- 8 Early experiments to measure the speed of light involved timing pulses of light being reflected back from distant mirrors. If a pulse of light was emitted and then detected 0.24 ms later, the distance to the mirror was

- A** 7.2×10^7 m
- B** 3.6×10^7 m
- C** 7.2×10^4 m
- D** 3.6×10^4 m

(Total for Question 8 = 1 mark)



- 9 The diagram represents straight wavefronts passing across a boundary from deep water into shallow water, with a change in speed and direction.

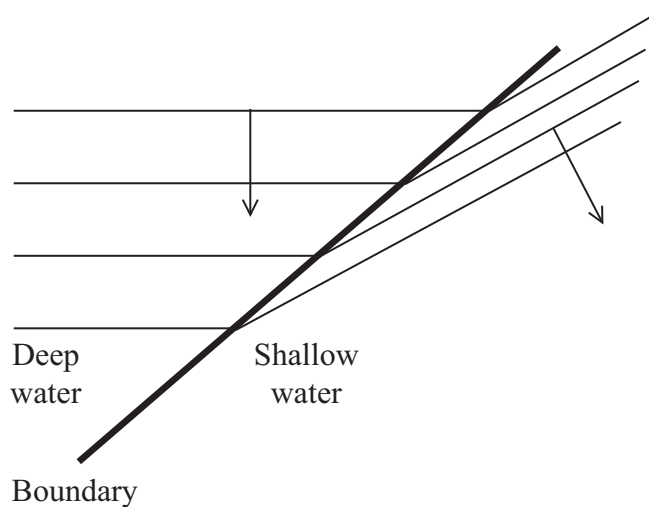

Which wave property does this diagram illustrate?

- A diffraction
- B interference
- C reflection
- D refraction

(Total for Question 9 = 1 mark)

- 10 Which of the following quantities is shown with the correct unit?

- A current and C s
- B potential difference and eV
- C power and J s
- D resistivity and Ω m

(Total for Question 10 = 1 mark)

TOTAL FOR SECTION A = 10 MARKS



SECTION B

Answer ALL questions in the spaces provided.

11 The photograph shows a solar panel being used to produce electricity.



The solar panel has an efficiency of 15%. The average radiation flux falling on the panel is 210 W m^{-2} .

Assuming that this radiation falls normally on the panel, calculate the area of the panel that would provide an average power output of 500 W.

(3)

Area =

(Total for Question 11 = 3 marks)



12 (a) A tiger's roar includes sounds at frequencies below the range of human hearing known as infrasound.

Infrasound of wavelength 45 m travels at 330 m s^{-1} in air.

Calculate the frequency of this infrasound.

(2)

Frequency =

(b) The roar of a tiger in a zoo can be heard by visitors at the entrance, even though the tiger can not be seen because there is a hill in the way.

Name and explain this effect.

(2)

(Total for Question 12 = 4 marks)



13 Waves may be transverse or longitudinal.

(a) The table shows three types of wave. Complete the table by putting tick(s) in the box(es) to show which waves are longitudinal.

(1)

Type of wave	Longitudinal
Radio waves	
Ultrasound	
Visible light	

(b) Some waves can be plane polarised. Explain why longitudinal waves cannot be plane polarised.

(2)

.....

.....

.....

.....

.....

.....

.....

(Total for Question 13 = 3 marks)



14 The diagram shows a circuit set up by a student.

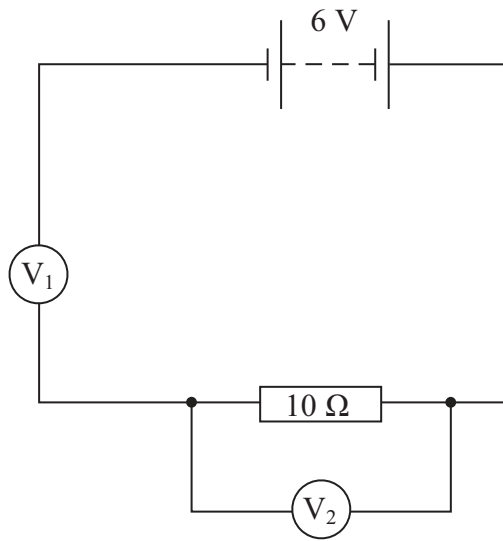

(a) Both voltmeters have a resistance of $10\text{ M}\Omega$. The reading on V_1 is 6 V and the reading on V_2 is zero.

Explain these readings.

(2)

.....

.....

.....

.....

.....

(b) The student replaces the $10\ \Omega$ resistor with a resistor of unknown resistance R . The reading on V_1 is now 4 V .

Calculate the value of R .

(3)

.....

.....

.....

.....

.....

$R =$

(Total for Question 14 = 5 marks)



16 A car battery has an e.m.f. of 12 V and an internal resistance of $3.0 \times 10^{-3} \Omega$. For the starter motor to turn the engine, the battery must provide a current of 400 A.

(a) Calculate the terminal potential difference across the terminals of the battery when the current through the battery is 400 A.

(3)

.....

.....

.....

.....

.....

Terminal potential difference =

(b) The copper wires between the battery and the motor have a diameter of 1 cm.

Explain why such a thick wire is needed.

(3)

.....

.....

.....

.....

.....

.....

.....

(Total for Question 16 = 6 marks)



17 (a) Show how the ohm is derived.

(1)

.....

.....

(b) The graphs show the current-potential difference (I - V) characteristics for a metal conductor and for a thermistor.

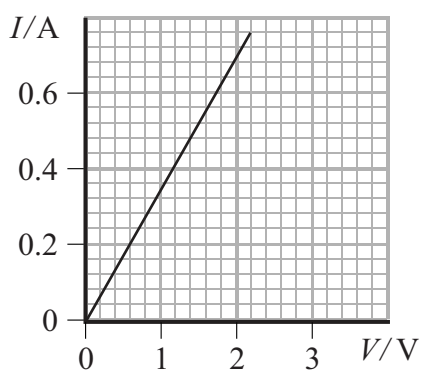

Metal conductor

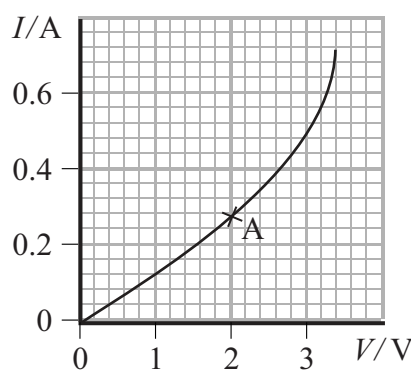

Thermistor

(i) Calculate the resistance of the thermistor at point A.

(2)

.....

.....

.....

Resistance =

(ii) Use the graphs to describe how the resistance varies with potential difference for each component.

(2)

.....

.....

.....

.....



(iii) Explain, in terms of electrons, why the thermistor behaves in this way.

(2)

.....

.....

.....

.....

.....

(Total for Question 17 = 7 marks)



18 Optical fibres have many uses in medicine and communications. They can also be incorporated into items such as the curtains shown in the photograph.



Some optical fibres are made from a central core of transparent material surrounded by a material of a different refractive index as a cladding.

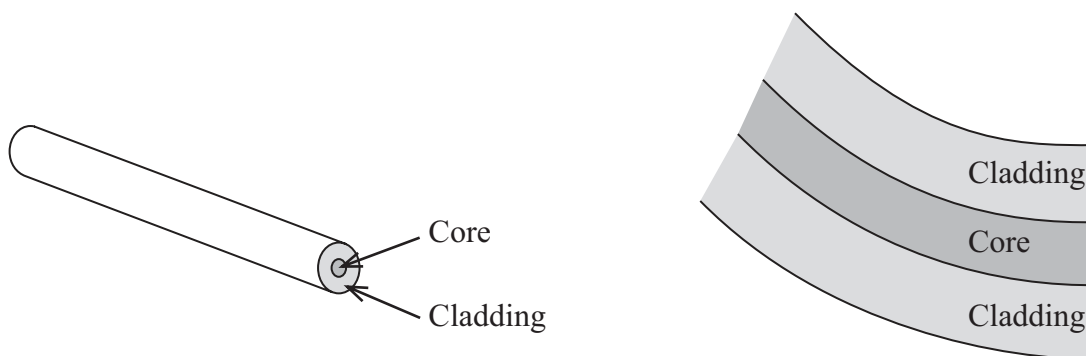

speed of light in the core = $1.96 \times 10^8 \text{ m s}^{-1}$
speed of light in the cladding = $2.03 \times 10^8 \text{ m s}^{-1}$

(a) Calculate the critical angle for the core-cladding boundary.

(3)

.....

.....

.....

.....

.....

.....

Critical angle =



(b) The diagram below shows a ray of light inside the core of a fibre. The ray is incident on the core-cladding boundary at an angle of 80° .

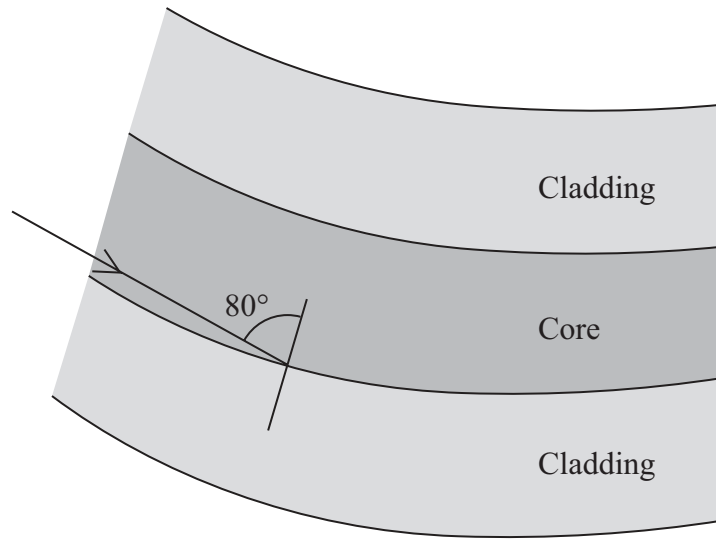

State what happens to this ray of light when it is incident on the core-cladding boundary as shown.

(1)

.....

.....

.....

(c) The light source for these curtains is at the top.

Suggest why the bottom of the curtain is much brighter than the rest of the curtain.

(2)

.....

.....

.....

.....

.....

(Total for Question 18 = 6 marks)



19 Energy is a very important concept in physics. Energy is usually measured in joules, but may be measured in electronvolts (eV) or kilowatt-hours (kW h).

- (a) In an X-ray tube an electron is accelerated across a potential difference of 100 000 V. The electron gains 100 000 eV of kinetic energy.

Calculate this energy in joules.

(2)

100 000 eV = J

- (b) A 1000 W domestic heater dissipates 8 kW h of energy when used for 8 hours.

Calculate the energy dissipated in joules.

(2)

8 kW h = J

- (c) Suggest why, in the above cases, the electronvolt and the kilowatt-hour are more convenient units than the joule.

(2)

(Total for Question 19 = 6 marks)



20 A gold leaf electroscope is used to detect very small amounts of charge. When the electroscope cap is negatively charged, electrons spread along the metal rod and the gold leaf so they both become negatively charged. The rod and leaf repel each other, so the gold leaf rises up.

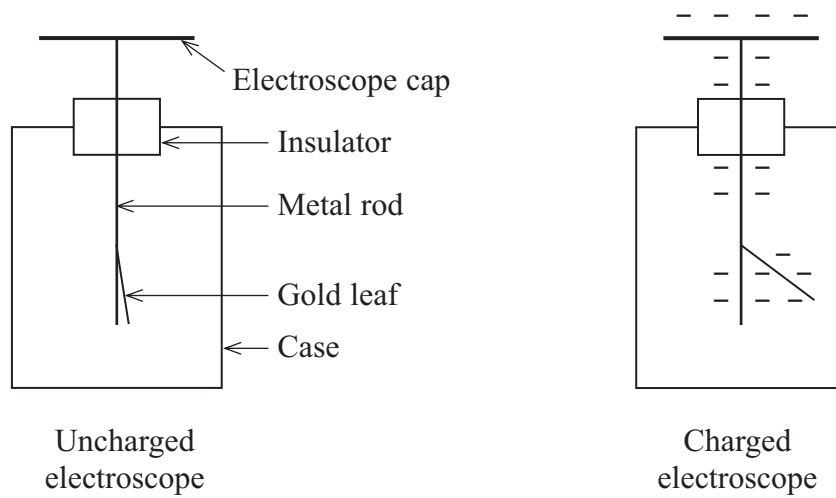

A gold leaf electroscope can be used to demonstrate the photoelectric effect. A clean zinc plate is placed onto the cap of the electroscope and the plate and electroscope are charged negatively. Ultraviolet radiation is shone onto the zinc plate.

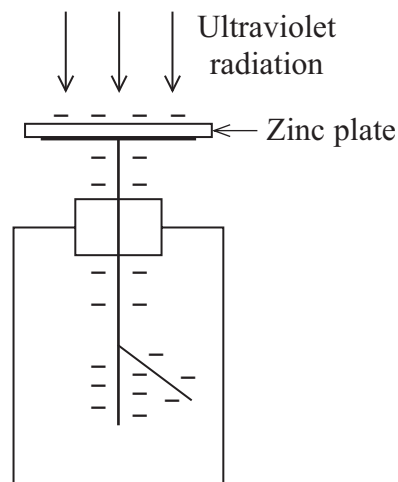

*(a) The gold leaf slowly falls.

Explain, with reference to the work function of zinc, why this happens.

(4)

.....

.....

.....

.....

.....

.....

.....

.....

.....

.....

.....

.....

.....

.....

.....

.....

.....

.....

.....

.....

.....

.....

.....

(b) Why is the effect not observed if the ultraviolet radiation is replaced by visible light?

(1)

.....

.....



21 (a) A transverse wave travelling along a wire under tension has a speed v given by

$$v = \sqrt{\frac{T}{\mu}}$$

where T is the tension in the wire and μ is the mass per unit length of the wire.

Show that the units on both sides of the equation are the same.

(3)

.....

.....

.....

.....

.....

.....

.....

.....

(b) The diagram shows a wire held under tension by hanging weights at one end and supported by a vibration generator at the other end. The frequency of the vibration generator is slowly increased from zero until a standing wave is formed.

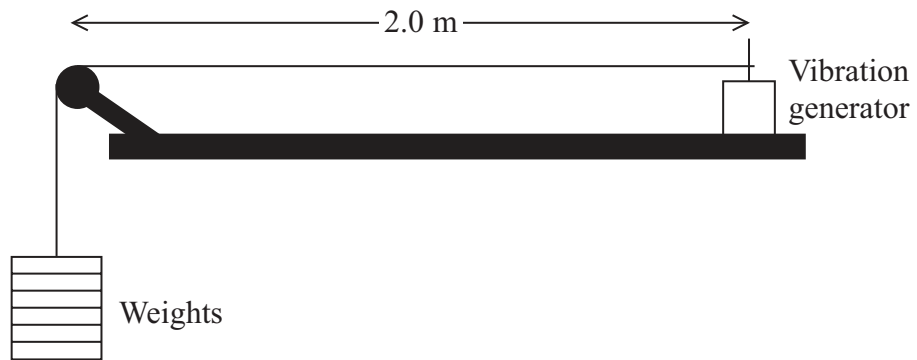

(i) Explain how the standing wave is produced.

(3)

.....

.....

.....

.....

.....

.....

(ii) Calculate the wavelength of the standing wave.

(1)

.....

Wavelength =

(iii) The weight is 150 N and the mass per unit length of the wire is 0.0050 kg m^{-1} .

Using the equation given in (a), calculate the speed of the transverse wave along the wire.

(2)

.....

.....

.....

.....

Speed of transverse wave =



(iv) The wire is observed as the frequency of the vibration generator is steadily increased to several times the frequency that produced the first standing wave.

Describe and explain what is seen as the frequency is increased.

(4)

.....

.....

.....

.....

.....

.....

.....

.....

.....

.....

.....

.....

.....

.....

.....

.....

.....

.....

.....

.....

.....

.....

(Total for Question 21 = 13 marks)

TOTAL FOR SECTION B = 70 MARKS

TOTAL FOR PAPER = 80 MARKS



List of data, formulae and relationships

Acceleration of free fall	$g = 9.81 \text{ m s}^{-2}$	(close to Earth's surface)
Electron charge	$e = -1.60 \times 10^{-19} \text{ C}$	
Electron mass	$m_e = 9.11 \times 10^{-31} \text{ kg}$	
Electronvolt	$1 \text{ eV} = 1.60 \times 10^{-19} \text{ J}$	
Gravitational field strength	$g = 9.81 \text{ N kg}^{-1}$	(close to Earth's surface)
Planck constant	$h = 6.63 \times 10^{-34} \text{ J s}$	
Speed of light in a vacuum	$c = 3.00 \times 10^8 \text{ m s}^{-1}$	

Unit 1

Mechanics

Kinematic equations of motion	$v = u + at$
	$s = ut + \frac{1}{2}at^2$
	$v^2 = u^2 + 2as$
Forces	$\Sigma F = ma$
	$g = F/m$
	$W = mg$
Work and energy	$\Delta W = F\Delta s$
	$E_k = \frac{1}{2}mv^2$
	$\Delta E_{\text{grav}} = mg\Delta h$

Materials

Stokes' law	$F = 6\pi\eta r v$
Hooke's law	$F = k\Delta x$
Density	$\rho = m/V$
Pressure	$p = F/A$
Young modulus	$E = \sigma/\epsilon$ where
	Stress $\sigma = F/A$
	Strain $\epsilon = \Delta x/x$
Elastic strain energy	$E_{\text{el}} = \frac{1}{2}F\Delta x$



Unit 2

Waves

Wave speed	$v = f\lambda$
Refractive index	${}_1\mu_2 = \sin i / \sin r = v_1/v_2$

Electricity

Potential difference	$V = W/Q$
Resistance	$R = V/I$
Electrical power, energy and efficiency	$P = VI$ $P = I^2R$ $P = V^2/R$ $W = VI t$

$$\% \text{ efficiency} = \frac{\text{useful energy output}}{\text{total energy input}} \times 100$$

$$\% \text{ efficiency} = \frac{\text{useful power output}}{\text{total power input}} \times 100$$

Resistivity	$R = \rho l/A$
Current	$I = \Delta Q/\Delta t$ $I = nqvA$
Resistors in series	$R = R_1 + R_2 + R_3$
Resistors in parallel	$\frac{1}{R} = \frac{1}{R_1} + \frac{1}{R_2} + \frac{1}{R_3}$

Quantum physics

Photon model	$E = hf$
Einstein's photoelectric equation	$hf = \phi + \frac{1}{2}mv_{\max}^2$

